

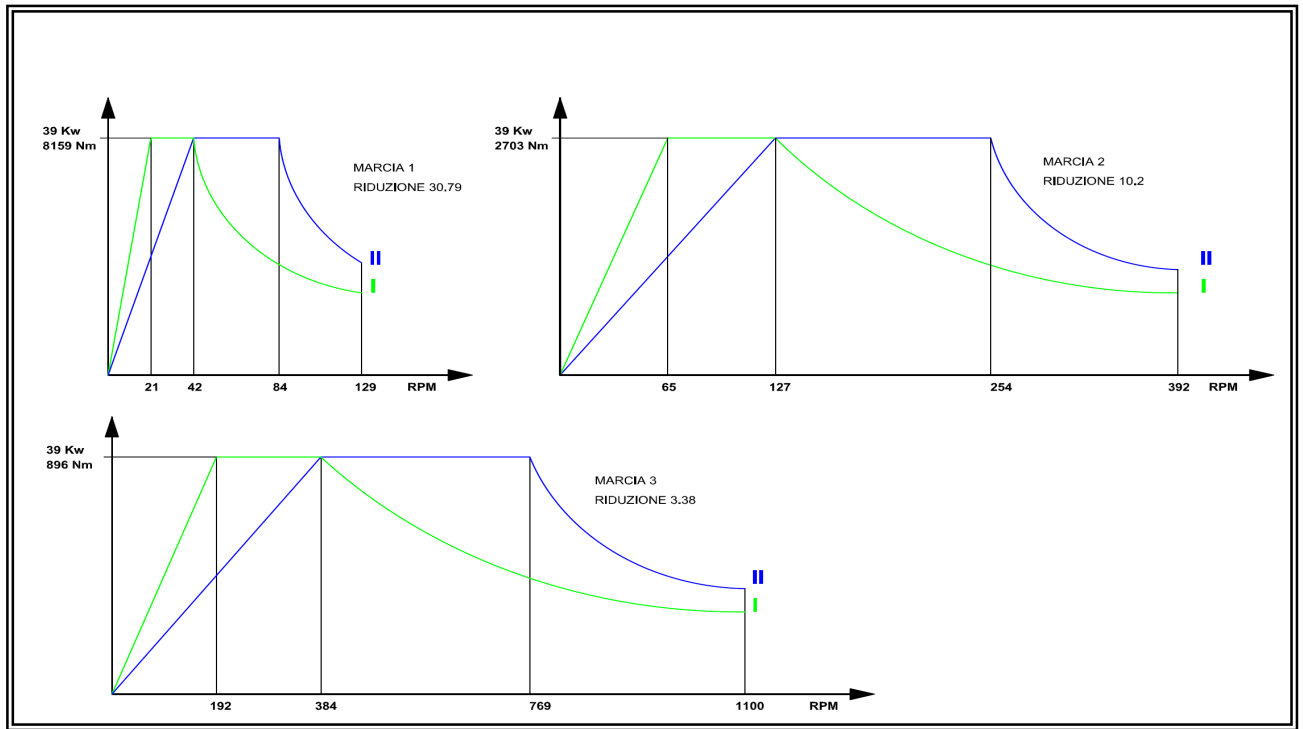

TITANO CNC DREHMASHINE		50	55	60	65	70
SPITZENHÖHE ÜBER BETT	mm	500	550	600	650	700
SPITZENABSTAND	mm	2000-3000-4000-5000-6000-7000-8000				
ZULÄSSIGER DURCHMESSER AUF BETT	mm	1000	1100	1200	1300	1400
ZULÄSSIGER DURCHMESSER AUF SCHLITTEN	mm	620	720	820	920	1020
BETTBREITE	mm	690				
KOPF						
SPINDELDURCHCLASS	mm	160 (OPT. 230 - 320)				
SPINDELNASE	ASA	11" (OPT. 15" - 20")				
GESCHWINDIGKEIT						
I	rpm	0 - 110				
II	rpm	0 - 330				
III	rpm	0 - 800 (0 - 500)				
GEGENREITSTOCK						
HOHLWELLENDURCHMESSER	mm	140				
HOHLWELLENLÄNGE	mm	300				
KONUS DER HOHLWELLE	CM	6				
ACHSEN						
LEISTUNG X-ACHSE	daN	1000				
LEISTUNG Z-ACHSE	daN	2000				
EILGANG BIS D.P. 4000 X-Z	m/min	7-15				
EILGANG ÜBER D.P. 4000 X-Z	m/min	7-10				
MOTOR						
LEISTUNG	Kw	39				
GEWICHT						
GEWICHT	Kg	12.000/20.000				

DIAGRAMM DREHMOMENT/LEISTUNG



FESTE LUNETTE		
B	mm.	200-400
B	mm.	400-680
B	mm.	700-960
B	mm.	900-1160

MITGEHENDE LUNETTE		
A	mm.	100-250

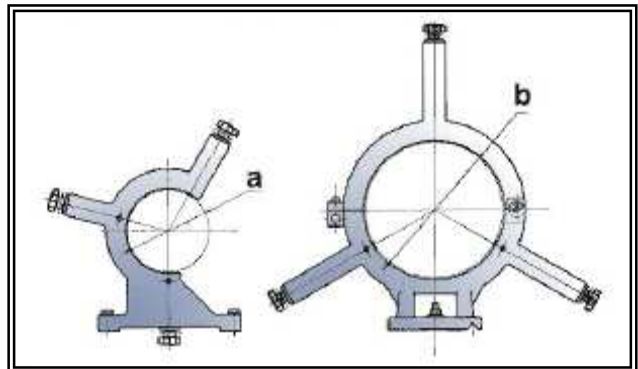

		A	B	D	d
TITANO 50	mm	500	543	1000	620
TITANO 55	mm	550	543	1100	720
TITANO 60	mm	600	543	1200	820
TITANO 65	mm	650	543	1300	920
TITANO 70	mm	700	543	1400	1020

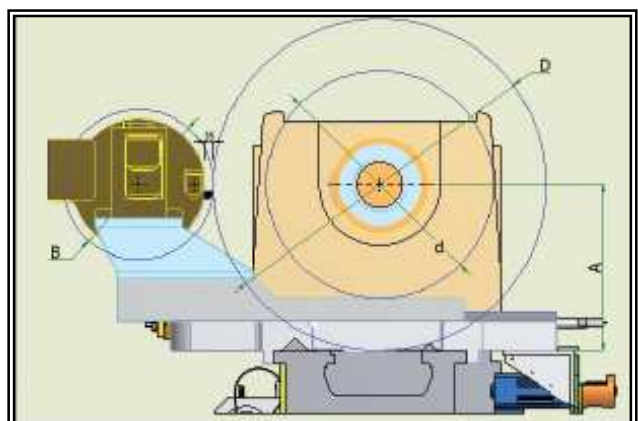

SPITZENABSTAND		DREHLANGE	
A		B	
2000	1600		
3000	2600		
4000	3600		
5000	4600		
6000	5600		
7000	6600		
8000	7600		

DIE BEARBEITUNGSFÄHIGE LÄNGE VARIIERT JE NACH MONTIERTEN SPINDELN UND WERKZEUGREVOLVER *

AUBENMASSE				
H.P.	D.P.	A	B	C
50-55	2000	6000	3300	2600
	3000	7000	3300	2600
	4000	8000	3300	2600
60-65	5000	9000	3300	2600
70	6000	10000	3300	2600
	7000	11000	3300	2600
	8000	12000	3300	2600

